

Instruction Manual for Adjustable Strobe Power Supply for LED Lights OPPS-30

1 . Product outline

- This product is an adjustable analog strobe power supply only for LED Lights. Please do not use it in addition to our company's LED Lights.
- When synchronized with a trigger from the external, LED turns on.
- Control emission of light width of LED to 10 μ SEC~1mSEC by the internal and external select.
- Control brightness level (the voltage) between 12~36V with a switch of front panel.
But please warn the greatest voltage in a different thing by LED Light to use.
- Output a warning running out of LED. (Front panel and the external open collector output.)
- Input power supply voltage AC100V 50/60Hz

2 . Accessories and appearance

- Accessories : Connector set for external trigger input 1 set
 : Connector set for warning output running out of LED 1 set
 : Instruction Manual (this sheet) 1 piece

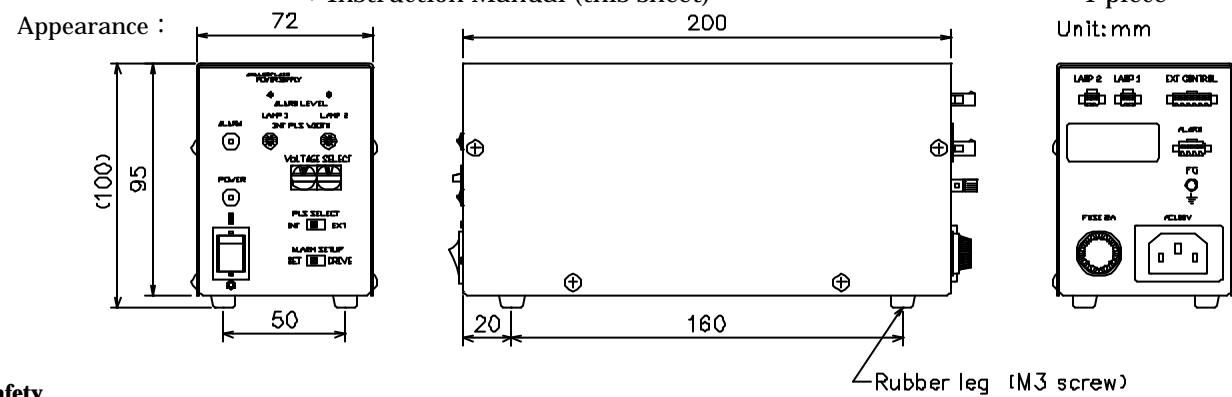

3 . Safety

Warning

(1)	Do not open the cover of a unit. There is a portion of high voltage in the inside of a power supply, and there is a possibility of receiving an electric shock in it.	
(2)	Connect directly the plug of a power supply to a wall socket. There is a cause of fire when you use an extension cable.	
(3)	Do not touch a power supply plug by the wet hand. There is a possibility of receiving an electric shock.	
(4)	Use a power supply, grounding it. When not grounded, there is a possibility of receiving an electric shock.	
(5)	When abnormalities to which a main part gets hot, a strange smell and/or smoke comes out arise, stop use immediately, shut off a power supply and pull out a power supply plug from a wall socket.	
(6)	Do not look at LED Light directly, it may have bad influence on your eyes.	

Cautions

(1)	Make connection of AC input cable and a LED Light cable after turning off the switch of a power supply unit.
(2)	Do not place any objects on a power supply.
(3)	Do not expose a power supply unit to sunlight or humidity directly.
(4)	When not used for a long period of time, pull out a power supply plug from the unit.
(5)	LED Light should be used at the strength of light at least in a half, when you use the constant light always, since a life will become short if used in the environment of a high temperature.
(6)	When abnormalities happen at a power supply unit, stop use immediately and contact to our company. Do not repair by the customer. (A product cannot be guaranteed, when a customer has an inside of a power supply changed or repaired.)

Product warranties

- 1 . If it should break down within the term of a guarantee(delivery-of-goods day for 12 months) under a customer's normal use condition based on notes, such as this handling description, or when initial [poor] accepts, We will carry out repair and exchange of a failure part gratuitously.
- 2 . However, We cannot guarantee on condition that external factors [, such as strong shock / natural disaster / water, steam oil, acid, radiation, etc.,], such as an error on use / use of the lighting equipment of those other than our company / unjust decomposition, and reconstruction / fall, etc.

4 . Specifications

4 - 1 Environment of operation

- Circumferential temperature : -10 ~ +40
 Circumferential humidity : 20 ~ 70% RH (Don't dew)

4 - 2 Input and output voltage

- Input voltage : AC100V (50/60Hz)
 Input current : 0 . 7 A (MAX) /100 V
 Output voltage : DC12 ~ 36V (variable, But 2ch becomes the same voltage.)
 Output current : 9A o-p (MAX)

(Attention) Load please use our designated LED Light with the voltage within an OPPS maximum set point of a product catalogue by all means.

4 - 3 Trigger (Detailed connection example please refer to 4-8)

- Voltage : DC 5 or 12 or 24V (Can supply only DC5V from a power supply)
 Current : 5~10mA
 period : More than 2.5mS (Less than 400Hz)

(Attention) When it is used by internal brightness control, more than 20mS, and please use it.
 Pulse width : 10 μ S ~ Less than 5% of a period (But it is best 1mS)
 Delay line : At the time of lighting about 2 μ S
 Lights out time about 4 μ S
 (But change by a load / connection cable length etc.)

A trigger period and a concrete example of pulse width.

Period (S)	Frequency (Hz)	Pulse width (S)
2.5m	400	10 μ ~ 125 μ
10m	100	10 μ ~ 500 μ
20m	50	10 μ ~ 1m
50m	20	10 μ ~ 1m

Trigger signal

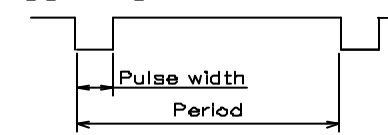

4 - 4 Control of brightness

- Method of control : The electronic flash emission of light by an external trigger signal
 System of control : Control emission of light time by pulse width (about 10 μ s ~ 1ms)
 (INT / EXT select in PLS SELECT)
 EXT : Control by pulse width of external trigger
 INT : Control by volume setting of INT PLS WIDTH
 (Variable range : 10 μ SEC ~ 900 μ SEC)
 Control emission of light strength by coordinating the voltage
 by VOLTAGE SELECT.
 (But the 2ch same voltage)

- Voltage range : DC12 ~ 36V
 (Hexadecimal switch and relations of the voltage please refer to 5-2.)
 256 step controls a with a switch.
 Addition, between 00 and 55 is DC12V become the constant output

Warning output : The ALARM output of LED open failure is outputted in an open collector circuit.

4 - 5 Protection function

- Over voltage protection : When an output electric current becomes about 9Ao-p,
 the output deteriorates.
 (But return automatically when the next trigger enters.)
 Protection of direct current trigger : After the trigger input, the output deteriorates
 after about 1~1.2mS.
 (But return automatically about 15mS later after output fall)
 Protection of unnecessary consecutive trigger : Refuse unnecessary consecutive trigger by an interlock circuit
 of Duty about 10~15:1.

4 - 6 Connectors

• Output connector (LAMP1, LAMP2) : SM connector SMP-02V-BC (Made by JST)

Pin No.	Signal
1	+
2	-



• External trigger input (EXT CONTROL) : SM connector SMP-06V-BC (Made by JST)

Pin No.	Signal	Color of option cable
1	+5V OUT	white
2	+5 ~ 2.4V IN	yellow
3	LAMP1 trigger input	brown
4	+5 ~ 2.4V IN	green
5	LAMP2 trigger input	red
6	GND	black

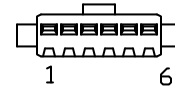

"OP-ECBS- " (is length [m]) should be used for and option cable.

(Attention) connect resistance with 2,4 pins, and please increase the voltage.

(Detailed connection example please refer to 4-8.)

• Warning output (ALARM) : SM connector SMP-04V-BC (Made by JST)

Pin No.	signal	Color of option cable
1	-	white
2	ALARM OUT	red
3	-	N/A
4	GND	black

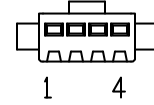

"OP-ACBS- " (is length [m]) should be used for and option cable.

• ALARM OUT becomes the open collector output. (greatest sink electric current : 100mA, greatest voltage : 30V)

4 - 7 Explanation of warning setting

When use a device first, set load of the LED Light side to a power supply every LED of use.

(To use a warning output function normally.)

(Attention) Perform setting in a stable state. (After about 30 minutes movement)

< procedure >

After having made a switch of front panel ALARM SETUP the SET side, give the ALARM volume to the right and can match a warning with lighting between non-lighting.

At the time of shipment, set the volume in the left. (The state that a warning is not over)

Maintain a normal consumption of LED Light.

Return a switch of front panel ALARM SETUP to a DRIVE side.

A warning outputs it when decrease by about 10% for a regular consumption,

and a lamp of ALARM turns on.

< Indication > ALARM : Turn on at the time of a warning by running out of LED.

(output it with an open collector.)

4 - 8 Connection example of a trigger circuit

Circuit example 1

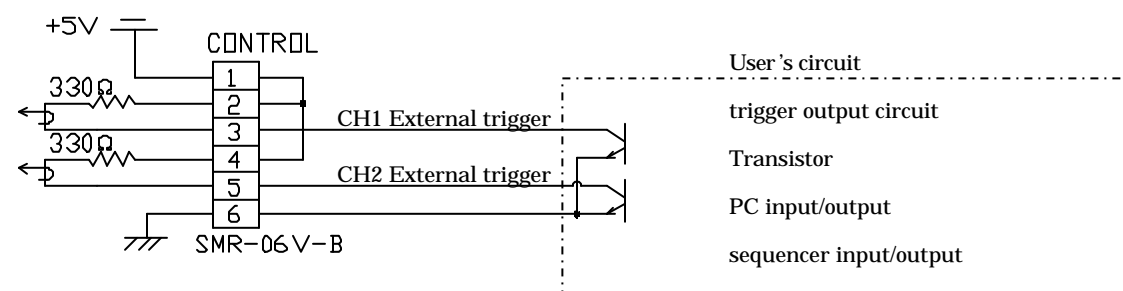

Circuit example 2

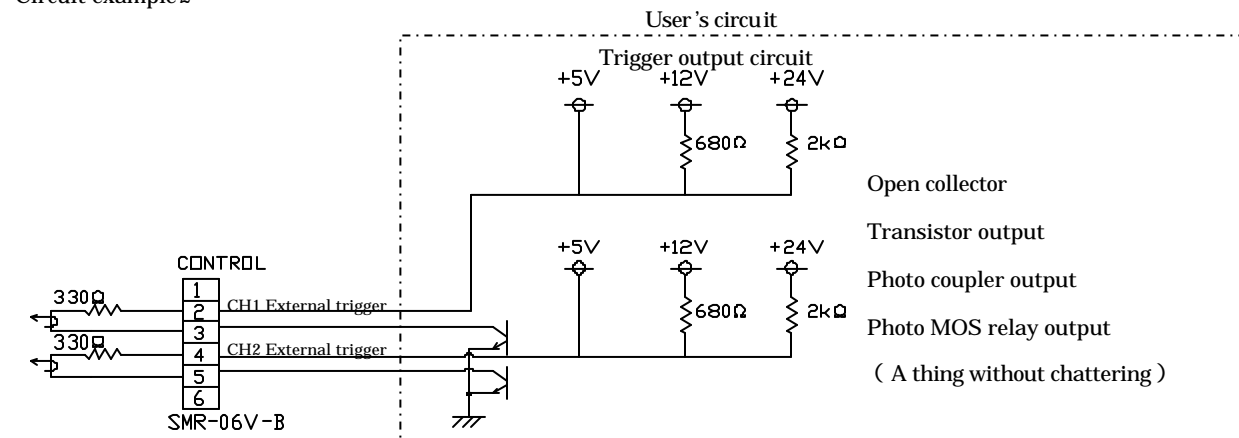

5 . Characteristic (reference value)

< measurement condition >

- Measurement temperature : 20
- Use load : White LED & Red LED
- connection cable : 50 c m

5 - 1 Add the voltage to LED

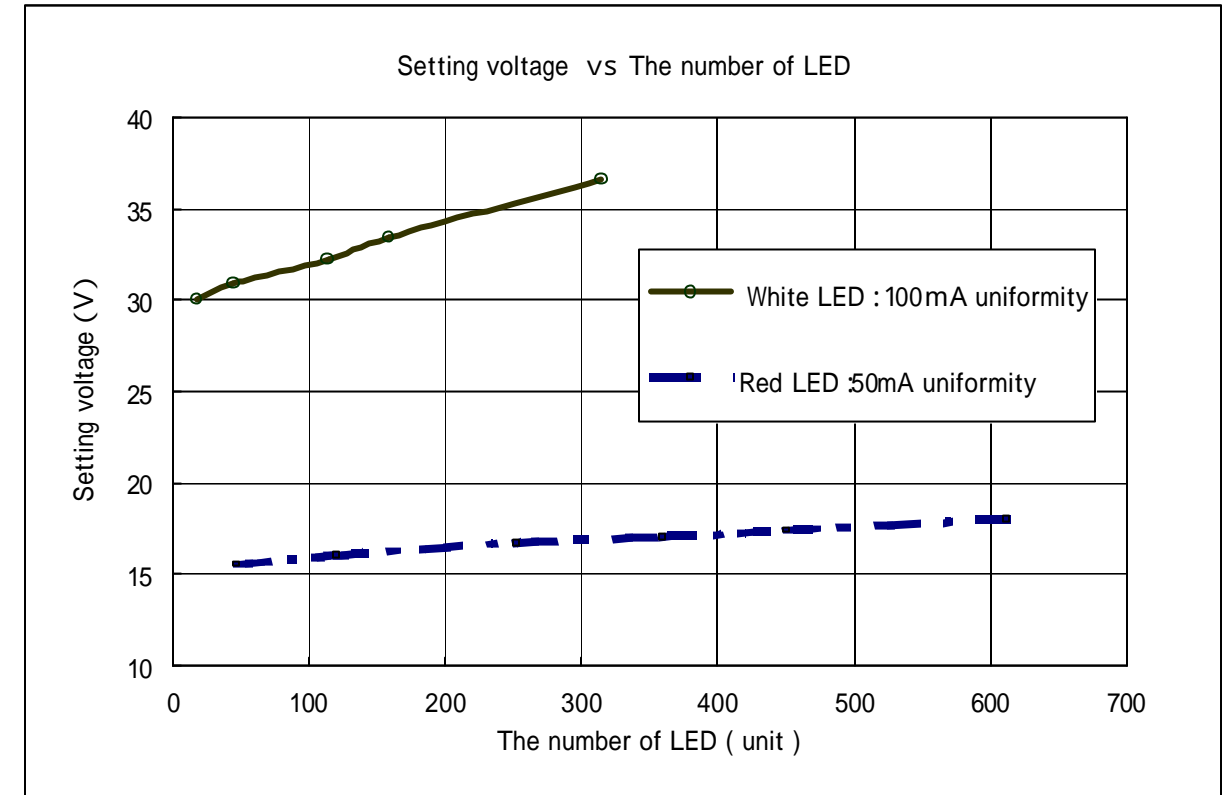

(Attention)

Please use it with the voltage within an OPPS set point of a product catalogue at the time of use.

5 - 2 Add the voltage to LED

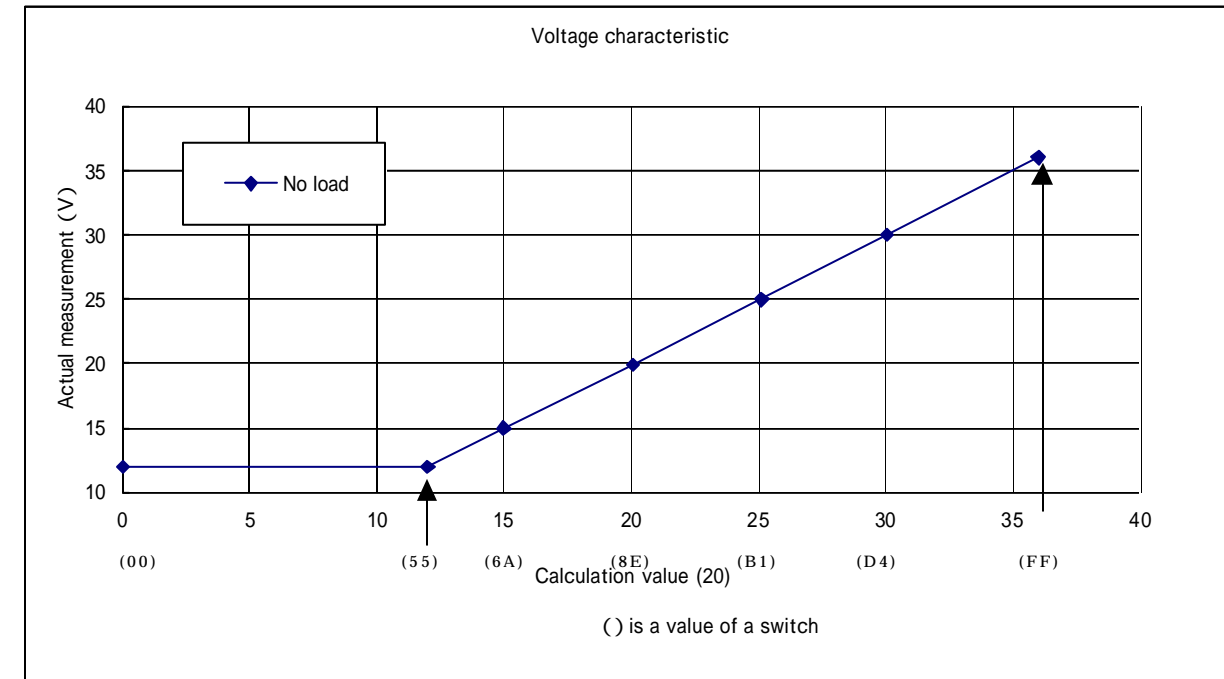

value of a switch	00	55	6A	8E	B1	D4	DB	E2	E9	F0	F7	FF
voltage (V)	12	12	15	20	25	30	31	32	33	34	35	36