

Instruction Manual for Adjustable digital Power Supply for LED Lights

OPPA-30M2 (30W Power supply)

1 . Product outline

- This product is a digital adjustment power supply only for LED Lights. Please do not use it in addition to our company's LED Lights.
- The LED Light brightness can be adjusted by 8bit signal control system. (Negative-true logic)
- This product operates under AC100V-240V.
- LED Light can be turn on/off with an external on/off control connector. (4 pin connector, EXT ON/OFF CONTROL)
- LED Light can be control at 256 step with an external brightness control connector. (18 pin connector, EXT CONTROL)
- There is less wiring than an article conventionally by a bus line method and latch method.

2 . Accessories and appearance

- Accessories : external on/off control connector set (4 pin connector) 1 set
 : external brightness control connector set (18 pin connector) 1 set
 : power cable (only AC100V) 1 piece
 : instruction manual (this sheet) 1 piece

Note : If you operate this product for input voltage exceeding AC100V, please prepare a suitable power cable by yourself

Appearance : OP-30M2

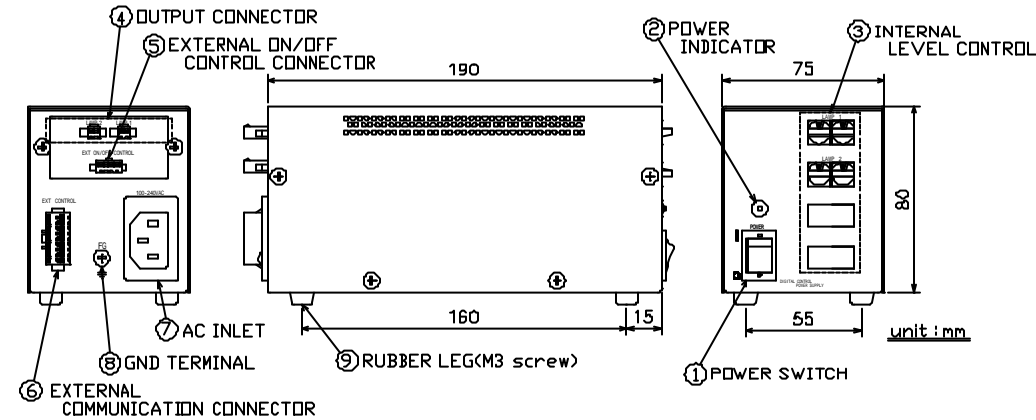

3 . Safety

Warning		Cautions	
(1) Do not open the cover of a unit. There is a portion of high voltage internal of a power supply, and there is a possibility of receiving an electric shock in it.		(1) Make connection of AC input cable and a LED Light cable after turning off the switch of a power supply unit.	
(2) Connect directly the plug of a power supply to a wall socket. There is a cause of fire when you use an extension cable.		(2) Do not place any objects on a power supply.	
(3) Do not touch a power supply plug by the wet hand. There is a possibility of receiving an electric shock.		(3) Do not expose a power supply unit to sunlight or humidity directly.	
(4) Use a power supply, grounding it. When not grounded, there is a possibility of receiving an electric shock.		(4) When not used for a long period of time, pull out a power supply plug from the unit.	
(5) When abnormalities to which a main part gets hot, a strange smell and/or smoke comes out arise, stop use immediately, shut off a power supply and pull out a power plug from a wall socket.		(5) LED Light should be used at the strength of light at least in a half, when you use the constant light always, since a life will become short if used in the environment of a high temperature.	
(6) Do not look at LED Light directly, it may have bad influence on your eyes.		(6) When abnormalities happen at power supply unit, stop use immediately and contact our company. Do not repair by the customer. (A product cannot be guaranteed, when a customer has an internal of a power supply changed or repaired.)	

Product warranties

- If it should break down within the term of a guarantee(delivery-of-goods day for 12 months) under a customer's normal use condition based on notes, such as this handling description, or when initial [poor] accepts. We will carry out repair and exchange of a failure part gratuitously.
- However, We cannot guarantee on condition that external factors [, such as strong shock / natural disaster / water, steam oil, acid, radiation, etc.], such as an error on use / use of the lighting equipment of those other than our company / unjust decomposition, and reconstruction / fall, etc.

4 . Specifications

4 - 1 Input and output voltage

- Input voltage : AC100V - 240V 0.8A/100V 0.4A/200V (MAX)
 Frequency of operation : 47 ~ 440Hz
 Rated output : DC12V 2.5A

4 - 2 Control of brightness

- Method of control : Approx.60KHz PWM control
 System of control : Digital (256-step control)
- Internal control of brightness : Control a set point (256 step of 00~ff) with a switch of the front panel. Turn on with a value setting when it was switched on.
- External control of brightness : When connected an external machinery and external control connector of back panel, control it at 256 step by signal control of 8bit of external control.
 A connection method please watch a connection example of external brightness control. (4 - 5)
- Range of control : 0 ~ 100% (At the environmental within the limits of operational condition)
- External on/off control : When connected an external machinery and external control connector of back panel, control LED Light when control a signal at an open collector or the relay point of contact.
 A connection method please watch a connection example of external control. (4 - 6)
- Protection circuit : LED Light turns off the light at the overload state the output. To remove it, switch off a power supply and exclude Light. After put a power supply once again, please.

4 - 3 Environment of operation

- Circumferential temperature : 10 ~ +40
 Circumferential humidity : 20 ~ 70%RH (Don't dew)

4 - 4 Connectors

- Output connector (LAMP 1 ~ 2) : SM connector SMP-02V-BC (Made by JST)

Pin No.	12V output type
1	Output + (+12V)
2	Output -



- External on/off control connector (EXT ON/OFF CONTROL) : SM connector SMP-04V-BC (Made by JST)

Pin No.	signal	Color of option cable
1	LAMP 1 ON/OFF	White
2	LAMP 2 ON/OFF	Green
3	External control change	Red
4	GND	Black

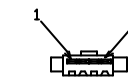

"OP-ECB2- " (is length[m]) should be used for an option cable.

- External brightness control connector (EXT CONTROL) : SM connector SMP-18V-BC (Made by JST)

Pin No.	Signal	Color of option cable	Pin No.	Signal	Color of option cable
1	2 ⁰	White	10	RESERVED	Pink
2	2 ¹	Red	11	RESERVED	Bright green
3	2 ²	Green	12	RESERVED	White / black
4	2 ³	Yellow	13	RESERVED	Red / black
5	2 ⁴	Brown	14	OPEN=ODD/GND=EVEN	Green / black
6	2 ⁵	Blue	15	RESERVED	Yellow / black
7	2 ⁶	Ash	16	INT/EXT SELECT	Brown / black
8	2 ⁷	Orange	17	GND	Black
9	LAMP 1,2 WRITE	Sky blue	18	RESERVED	Ash / black

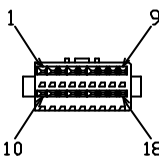

"OP-ECBA- " (is length [m]) should be used for an option cable.

4 - 5 Connection example of external brightness control (EXT CONTROL)

- Turn into external brightness control when short-circuit in 16pin and 17pin in an external control brightness connector. Write a set point (1~8pin) in 9~12pin after doing select of a channel setting in 14pin.
 (Odd number channel =OPEN/Even number channel =GND)
 Set control of light in 8bit signal (Negative-true logic, ON=GND / OFF=OPEN) and can control it at 256 step. In addition, all the set points of external brightness control are reset in main body power supply off.

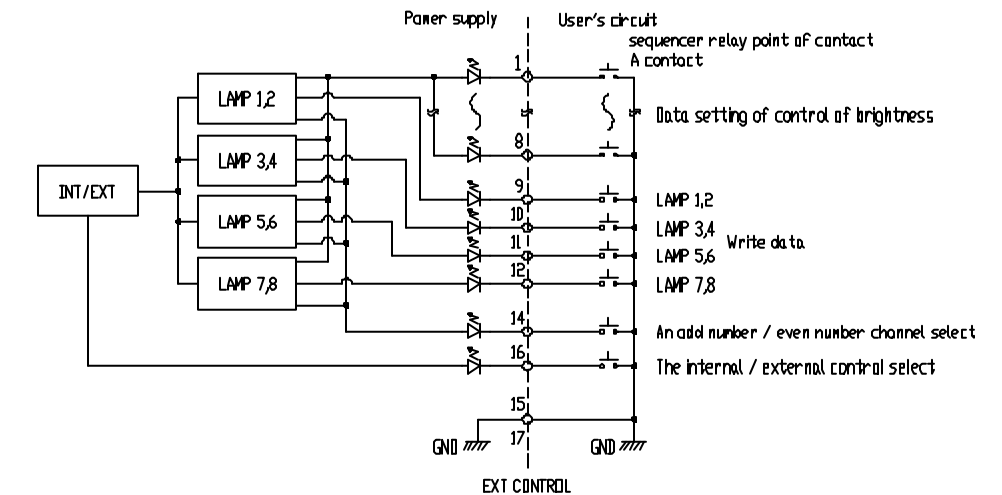

4 - 6 The method of external on/off control (EXT ON/OFF CONTROL)

- In order to work the external control function, short pin #3 and pin #4 circuit. (LED putting out lights)
 Under the above condition, when short the pin #1 and pin #4 circuit, LED Light (connected to ch1) will light on. Furthermore, when short pin #2 and pin #4 circuit, the LED Light (connected to ch2) will light on. (The INT/EXT control perform 2ch simultaneously.)

Recommend circuit

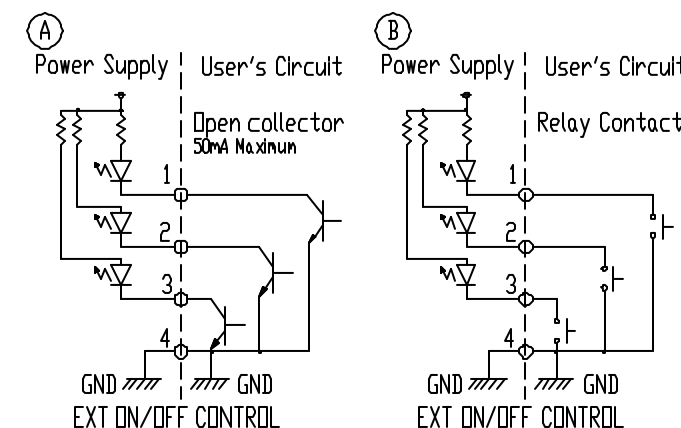

There are approx. 10mA current from pin#1,2... to pin#4. Please see a margin and use the open collector circuit with the current capacity of about 50mA.

4 - 7 Timing chart of external brightness control

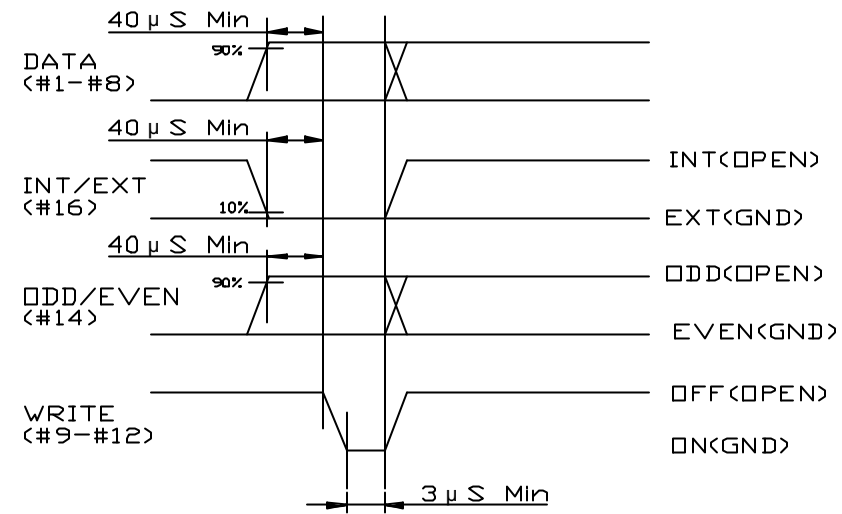

(Attention 1) Set each signal of data · INT/EXT · ODD/EVEN, and send a write signal, and please maintain it more than 3 micro seconds after progress more than 40 micro seconds.
 (Attention 2) Data become negative-true logic (ON=GND OFF=OPEN).

5 - 2 Delay line at the time of external control
 Lighting time (ON) : about 1.6 μ S, Lights out (OFF) : about 33 μ S

5 . Reference data

5 - 1 Going straight characteristics of PWM brightness control

